

MF12025



Size : 120 x 120 x 25mm (4.71 x 4.71 x 1.0inch)
 Motor : Shaded Pole
 Frame : Aluminum Die-Cost
 Impeller : PBT + 30% Fiber Glass. UL94V-0
 Lead Wire : 1007# 22AWG. UL/CSA
 Insulation Resistance :
 Min 10 M Ohm at 500VDC Between Terminal and the Frame
 Dielectric Strength : 1 min at 1,500VAC 50/60Hz
 Bearing Type : B: 2 Ball Bearing. S: Sleeve Bearing
 Operating Temp :
 Ball Bearing: Within -20 ~ 80°C
 Sleeve Bearing: Within -10 ~ 56°C
 Life Expectancy : Ball Bearing: 50,000 hours at 60°C
 Sleeve Bearing : 20,000 hours at 45°C
 Net Weight : 338 grams

120x120x25 mm

Fan guard corresponding model			
Metal	Plastic	Plastic filter	Ventilator Filter
FG-120	FF-120	FS-120	MA-04

Part No.	Bearing system	Rated Voltage (V)	Freq (Hz)	Current (A)	Input Power (W)	Speed (rpm)	Air Flow (CFM)	Static Pressure (Inch-H ₂ O)	Noise Level (dB-A)	Weight (g)
12025A1HSAT(L) 12025A1HBAT(L)	Sleeve Ball	110/120	50/60	0.19/0.18	14/17	2500/2700	70/85	0.13/0.18	40/44	338
12025A2HSAT(L) 12025A2HBAT(L)	Sleeve Ball	220/240	50/60	0.09/0.08	14/17	2500/2700	70/85	0.13/0.18	40/44	338
12025A1LSAT(L) 12025A1LBAT(L)	Sleeve Ball	110/120	50/60	0.08/0.07	6/8	2000/2200	56/64	0.11/0.13	33/37	338
12025A2LSAT(L) 12025A2LBAT(L)	Sleeve Ball	220/240	50/60	0.04/0.03	6/8	2000/2200	56/64	0.11/0.13	33/37	338
12025DVHBAL	Ball	110/120 220/240	50/60	0.19/0.18 0.09/0.08	14/17	2500/2700	70/85	0.13/0.18	40/44	338

Specifications subject to change without notice.

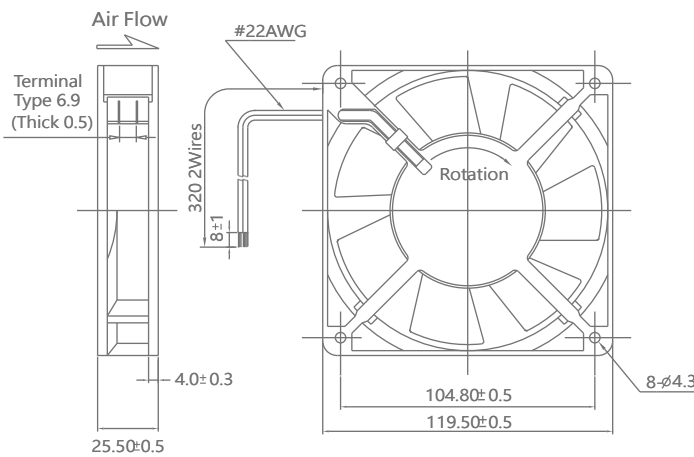

Units:mm

